

REVISIONS			
REV	CHANGE DESCRIPTION	DATE	NAME
01	INITIAL RELEASE		AMKOM

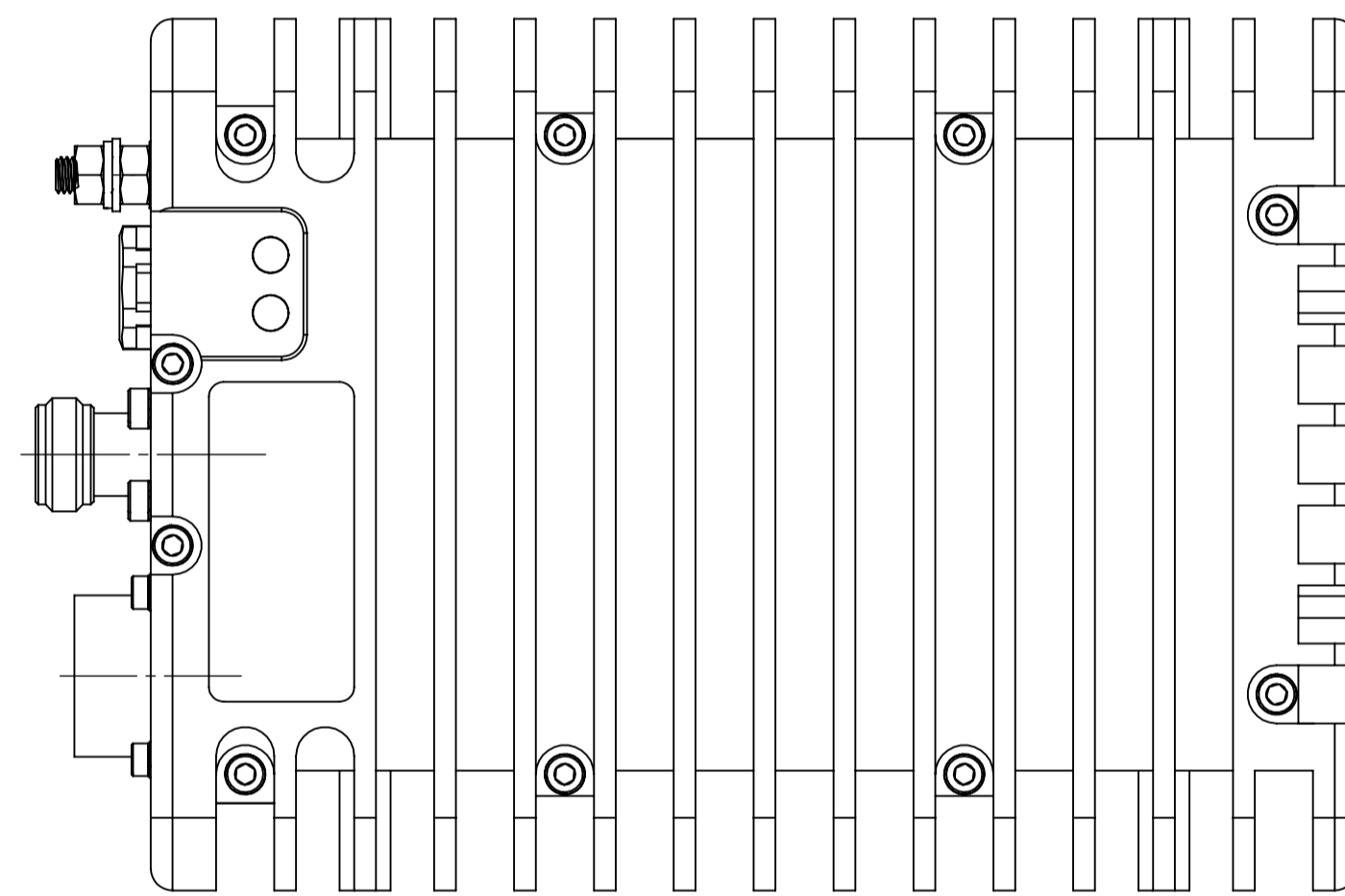

WR75 SEALED WAVEGUIDE OUTPUT

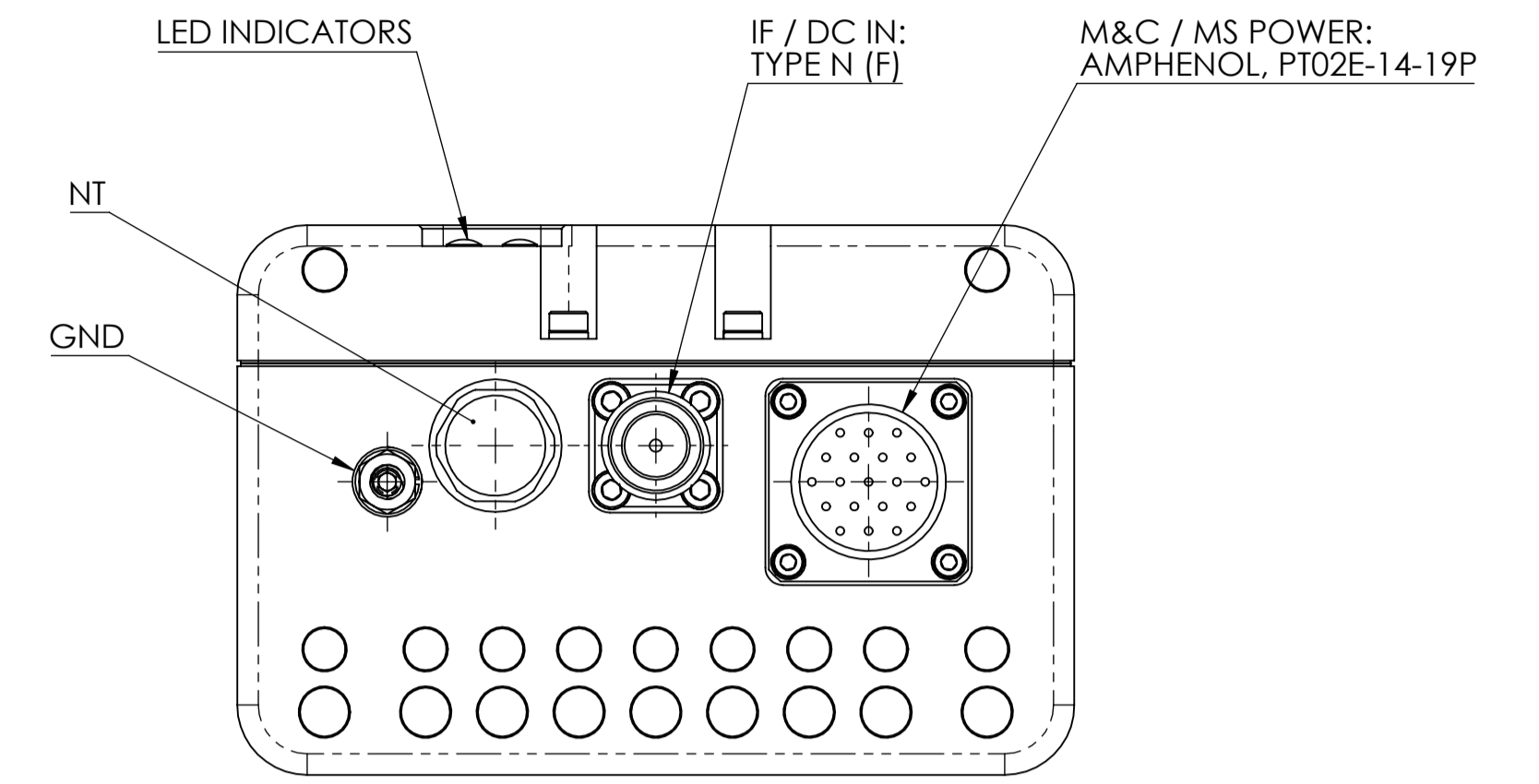
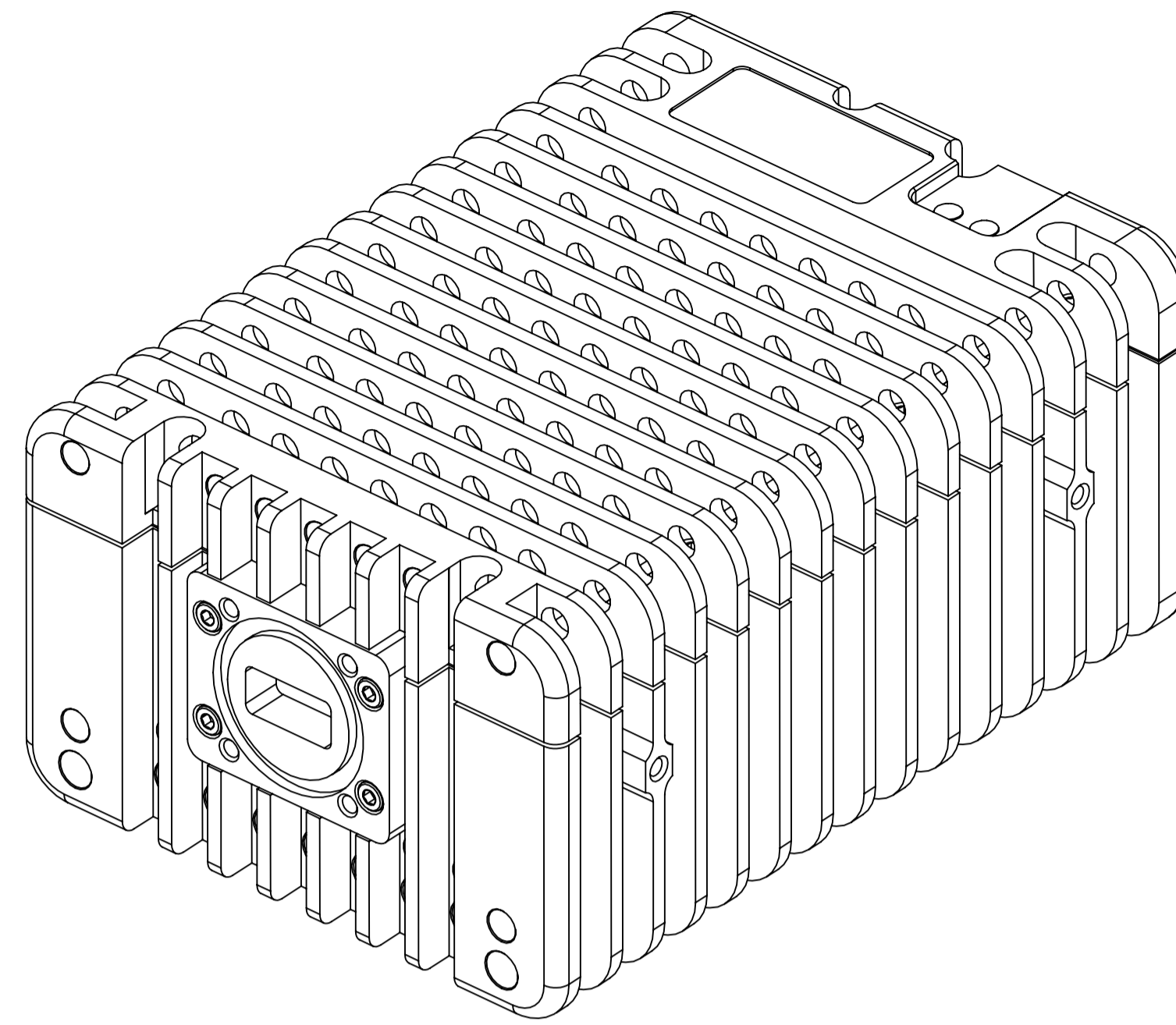
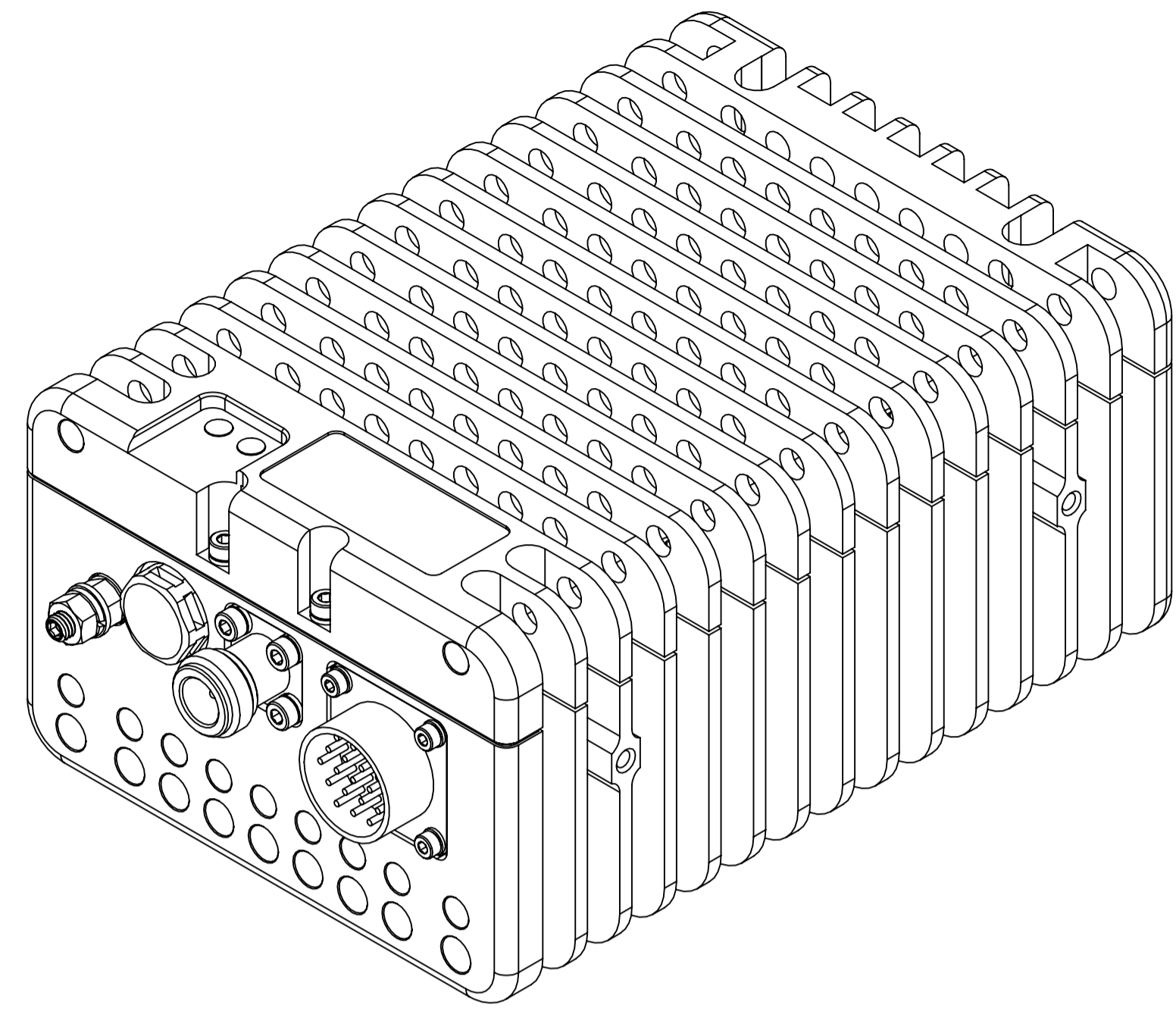
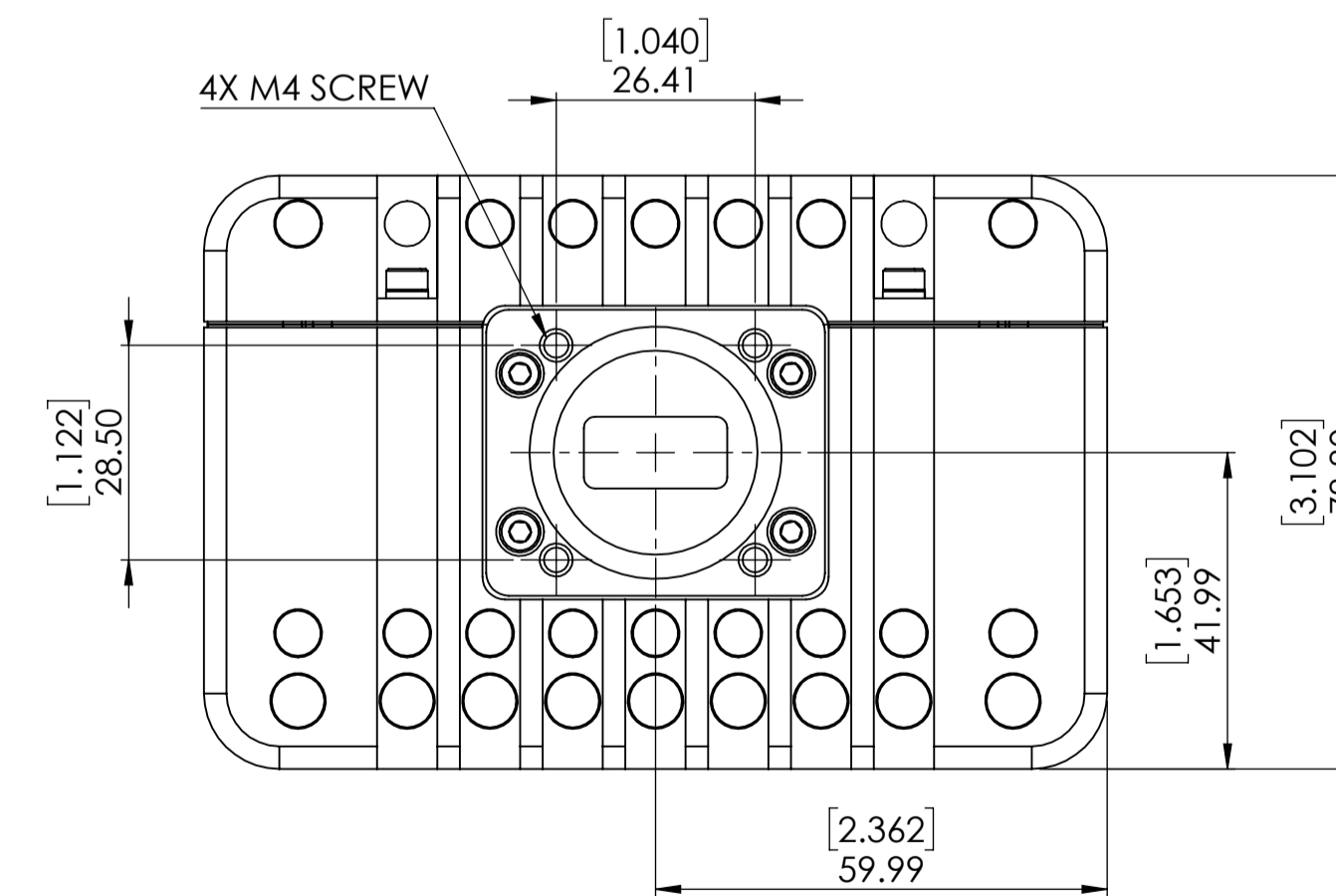
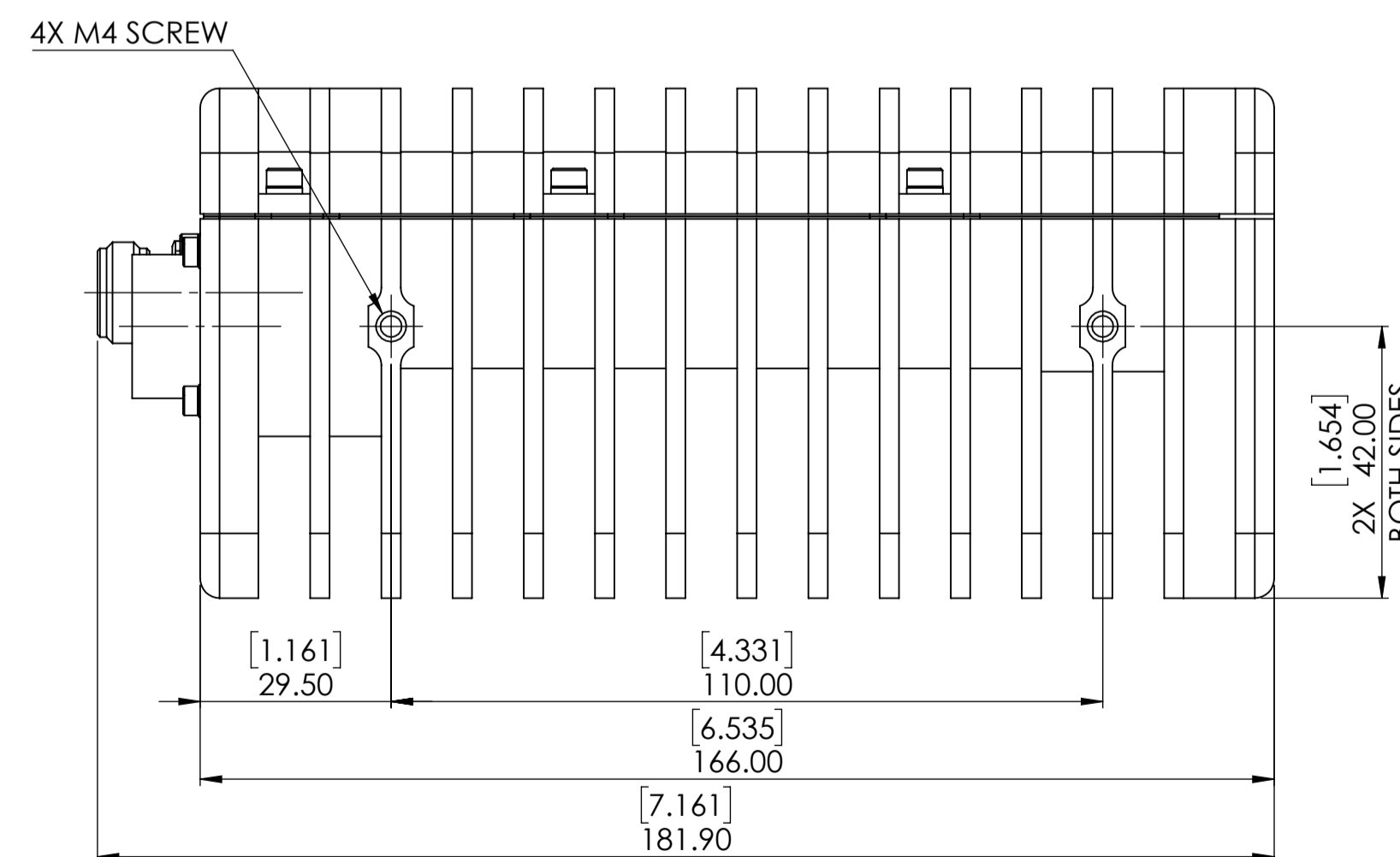
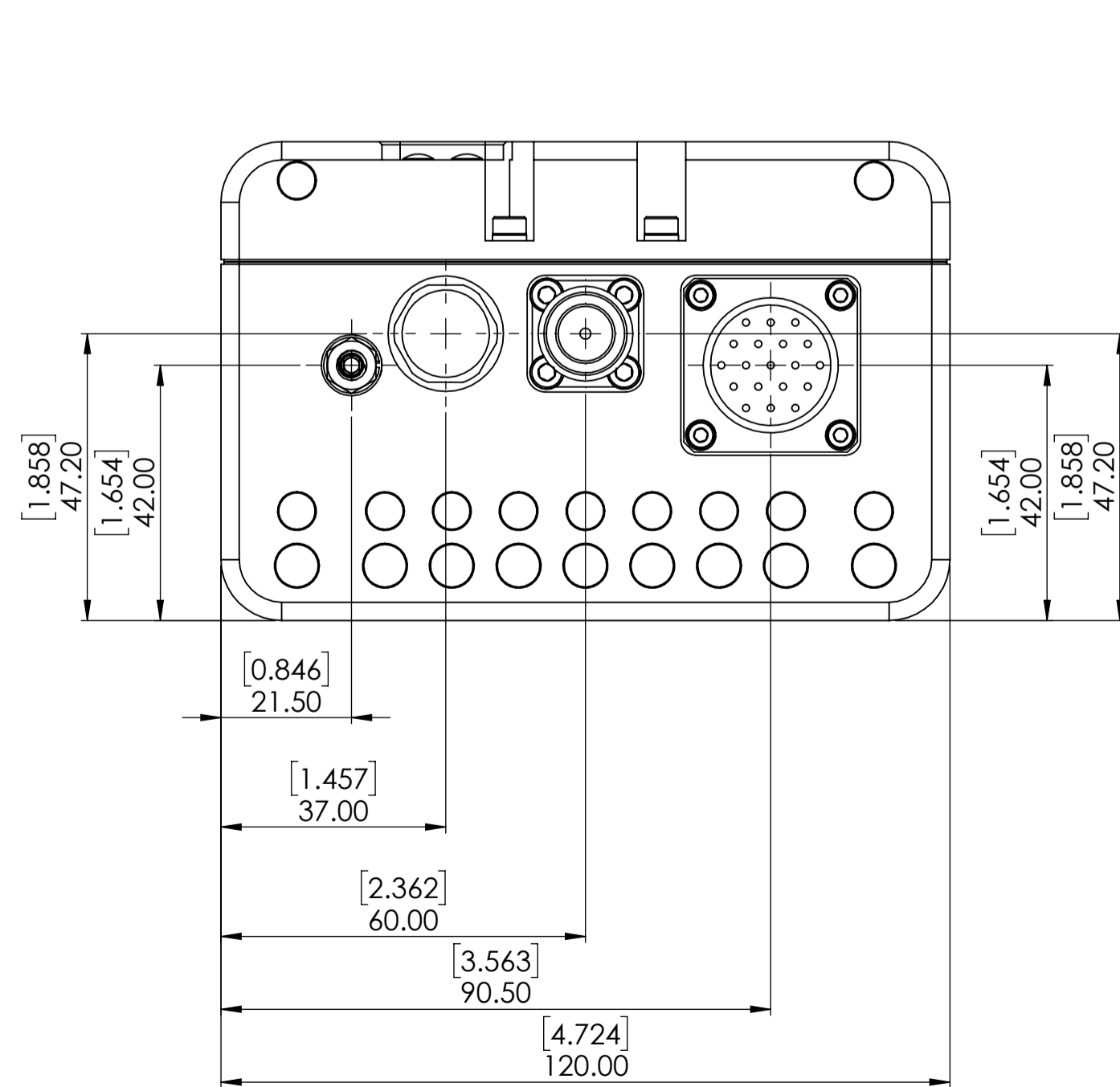
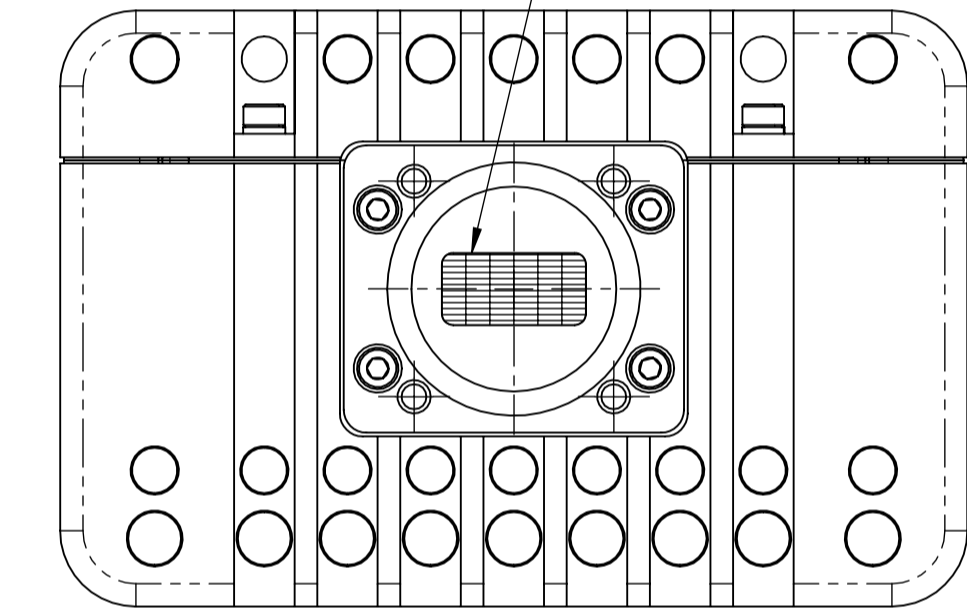

THIS DOCUMENT CONTAINS PROPRIETARY TRADE SECRET AND CONFIDENTIAL INFORMATION WHICH IS THE PROPERTY OF AMKOM DESIGN GROUP INC. THIS DOCUMENT AND THE INFORMATION IT CONTAINS ARE NOT TO BE COPIED, DISTRIBUTED, OR DISCLOSED TO OTHERS, OR USED IN ANY MANNER OUTSIDE OF AMKOM DESIGN GROUP INC WITHOUT PRIOR WRITTEN APPROVAL OF AMKOM DESIGN GROUP INC.

UNLESS OTHERWISE SPECIFIED DIMENSIONS ARE IN MILLIMETERS. TOLERANCES AS SHOWN BELOW	
LINEAR	ANGULAR
X ± 1	X ± 2°
X.X ± 0.25	X.X ± 1°
X.XX ± 0.1	

INTERPRET DIMENSIONS AND TOLERANCES PER ISO OR ASME Y14.5M-1994  
 DIMENSIONS SHOWN ARE FINISHED SIZES AND SHALL ALLOW FOR PLATING AND COATING, BUT NOT PAINTING  
 GENERAL THREAD FIT 6H 6g



Amkom Design Group Inc.	
DESCRIPTION AFK 16-20W BUC ASSEMBLY	
SIZE A1	PART NUMBER
REV 01	SHEET 1 OF 1