

# AKL-20W

## GaAs + GaN Technology

Low cost 20W low Ku-Band BUCs



### FEATURES:

- Low Cost Solution
- Extreme Efficiency, Stability, Reliability and Performance
- Hyper-Light Package, Only 1lbs
- Super Low Power Consumption (75W\* @20W)
- High Temperature Mode - up to + 60°C
- IP68 150,000 Hr Long Life Fan
- Exceeds ALL IESS-308/309 Phase Noise Standards
- 3 Year Warranty



### DESIGN OVERVIEW:

The low cost low Ku-Band BUCs are above and beyond the next generation of the World's Smallest feed-horn & boom-arm mountable BUCs in the industry, weighing only 1lbs and handling output power of 20W at the Ku-Band frequencies. We've picked the most mature, reliable and proven to be highly efficient amplifiers with internal overdrive protection. Each unit is vigorously tested at our California facility according to our ATP (Acceptance Testing Procedure).

### PERFORMANCE SPECIFICATIONS

<b>Operating RF Frequency</b>	AKL 12.75 - 13.25 GHz
<b>Operating IF frequency</b>	950 - 1450 MHz
<b>Local Oscillator</b>	11.80 GHz
<b>Rated Output Power PSAT</b>	20W 43.0 dBm
<b>Linear Power SR @ -26dBc PLIN</b>	16W 42.0 dBm
<b>IMD3 (two tones) 3dB Back Off</b>	-25 dBc max. 2 signal 5MHz apart at P-LINEAR
<b>Spectral Regrowth at PLINEAR</b> (QPSK at 1.5x and OQPSK at 1.0x symbol rate offset with 2dB back-off from rated power)	-30 dBc

### SPURIOUS & PHASE NOISE

<b>In-Band/Out-band Spurious</b>	-60dBc max.	
<b>Group Delay</b>	Ripple 1 nsec point to point max.	
<b>AM/PM Conversion</b>	1.0°/dB max. at 3 dB output backoff	
<b>Noise Power Density (TX)</b>	-85dBm/Hz	
<b>Noise Power Density (RX)</b>	-155dBm/Hz (10.95 - 12.75 GHz)	
<b>Phase Noise (Up Converter) (Ext. Ref.)</b>	-55 dBc/Hz @ 10 Hz	-115dBc/Hz
	-65 dBc/Hz @ 100 Hz	-135dBc/Hz
	-75 dBc/Hz @ 1 kHz	-150dBc/Hz
	-85 dBc/Hz @ 10 kHz	-155dBc/Hz
	-95 dBc/Hz @ 100 kHz	-160dBc/Hz

### POWER CONSUMPTION

<b>20W 43.0 dBm PSAT</b>	75W
<b>16W 42.0 dBm PLIN</b>	65W

### COMPLIANCE INFORMATION

MIL - STD - 188/164C	MIL - STD - 461	ROHS, REACH, WEEE
MIL - STD - 810E	DO - 160 G	

### PROTECTION

VOLTAGE	OVERTEMP	CURRENT
SMART ALARMS IN THE M&C	MICROPHONIC	

## ENVIRONMENT SPECIFICATIONS

<b>Environmental MIL-STD</b>	Compliant with MIL-STD810E
<b>Vibration MIL-STD</b>	MIL-STD810F, Method 514.5 C-2 Transport
<b>Operating Temperature Range</b>	- 40° C to + 70°C
<b>Storage Temperature Range</b>	- 60°C to + 85°C
<b>Humidity</b>	100% Condensing, IP67
<b>Shock</b>	20 g peak, 11 msec, 1/2 sine
<b>Altitude</b>	50,000ft, 15,240m
<b>Fan Rating / Field Replaceable</b>	IP 68, Long Life

## M&C INTERFACE

<b>Advanced Monitor &amp; Control</b>	RS232 (RS48, Ethernet Web Page Based, Telnet)*
<b>ALARMS</b>	PLL LOCK, HPA, MUTE, TX
<b>Stealth PLin Operation Mode</b>	LED Shut-Off   Silenced fan

## PART NUMBERING SYSTEM

- S - Slim Size Series
- F - Fan-less Series
- G - Fan-less and Slim Series
- KU - Universal Ku-Band 13.75 - 14.50 GHz
- KS - Standard Ku-Band 14.0 - 14.50 GHz
- KL - Low Ku-Band 12.75 - 13.25 GHz
- KD - Dual Ku-Band 13.75 - 14.50 GHz | 14.0 - 14.50 GHz
- 8 | 10 | 12 | 16 | 20 - Rated Power in Watts
- N | F - 50 Ohm or 75 Ohm IF Input Connector Type
- M1 - M&C Option RS232 Only
- M2 \* - RS232/485, Ethernet, SNMP, Telnet
- R - 10 MHz Ref. Auto Sense | Internal Reference
- U - Universal Mounting Bracket

\* Advanced M&C option coming soon

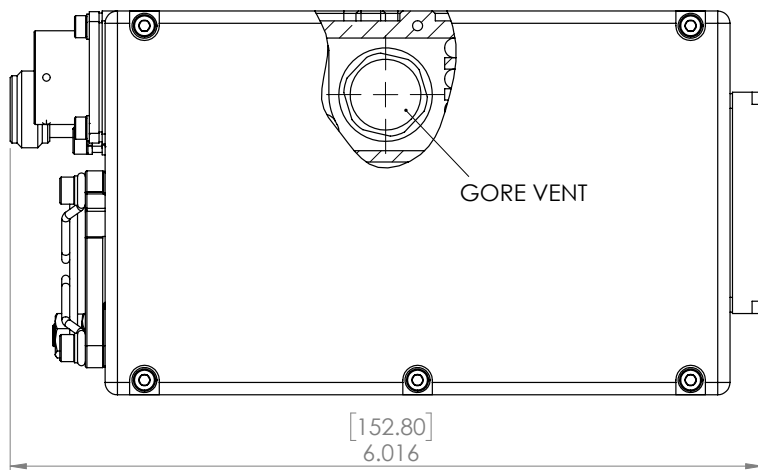

## INPUT|OUTPUT INTERFACE

<b>IF Connector</b>	N-type (50 Ohm)   F-type (75 Ohm)
<b>Universal Prime Power via IF</b>	+ 18 - 55 VDC
<b>Output Interface</b>	WR75 Sealed & Grooved

## GAIN

<b>Gain (Temperature Compensated)</b>	55 dB(min) 60 dB(typ.)
<b>TX Gain Flatness</b>	± 0.75 dB max. over 40 MHz
<b>TX Gain variation 50MHz</b>	± 0.5 dB
<b>TX Gain variation 500MHz</b>	± 1.5 dB

## MECHANICAL SPECIFICATIONS

<b>Dimensions</b>	5.4" x 3.1" x 2.3" (137 × 78 × 59mm)
<b>Weight</b>	1lbs (0.45kg)

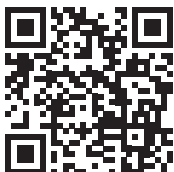
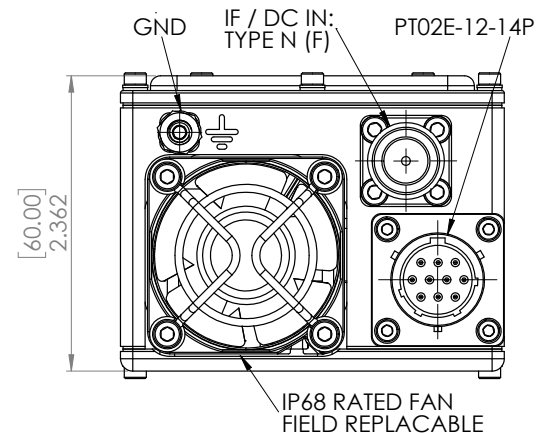
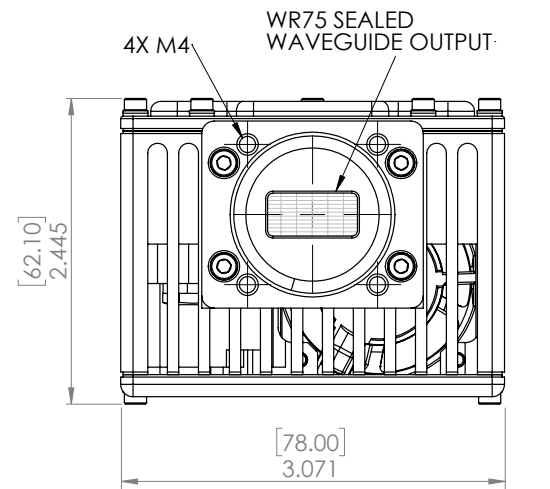

Visit Product Page