

8 7 6 5 4 3 2 1

D

D

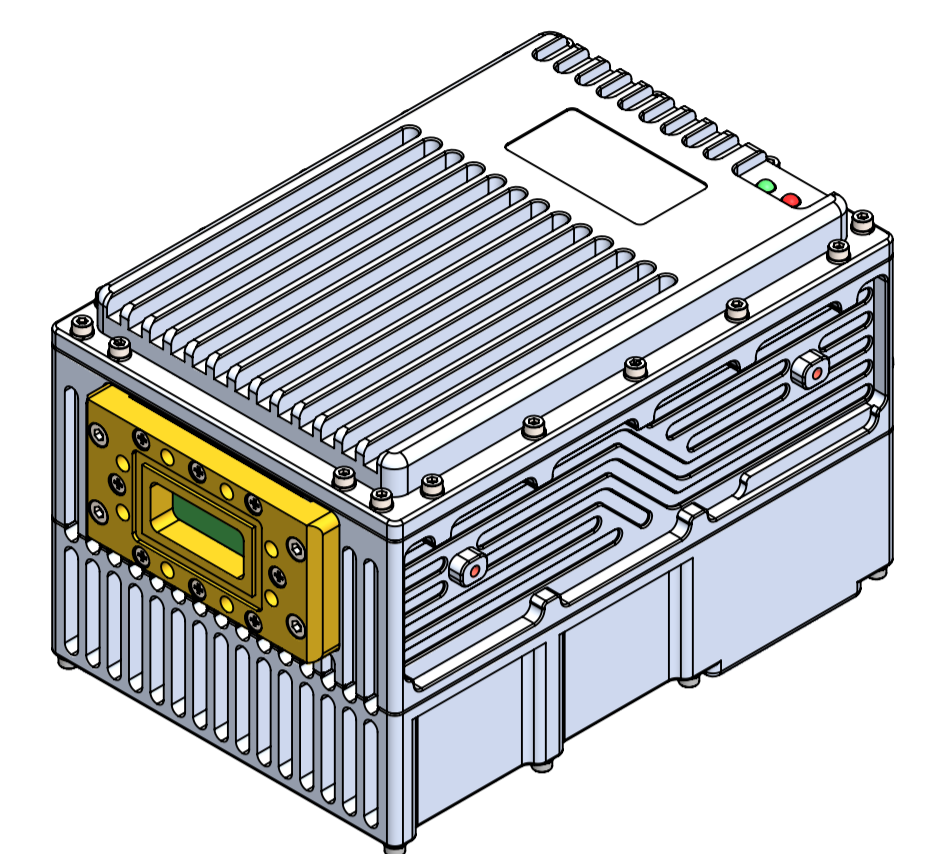
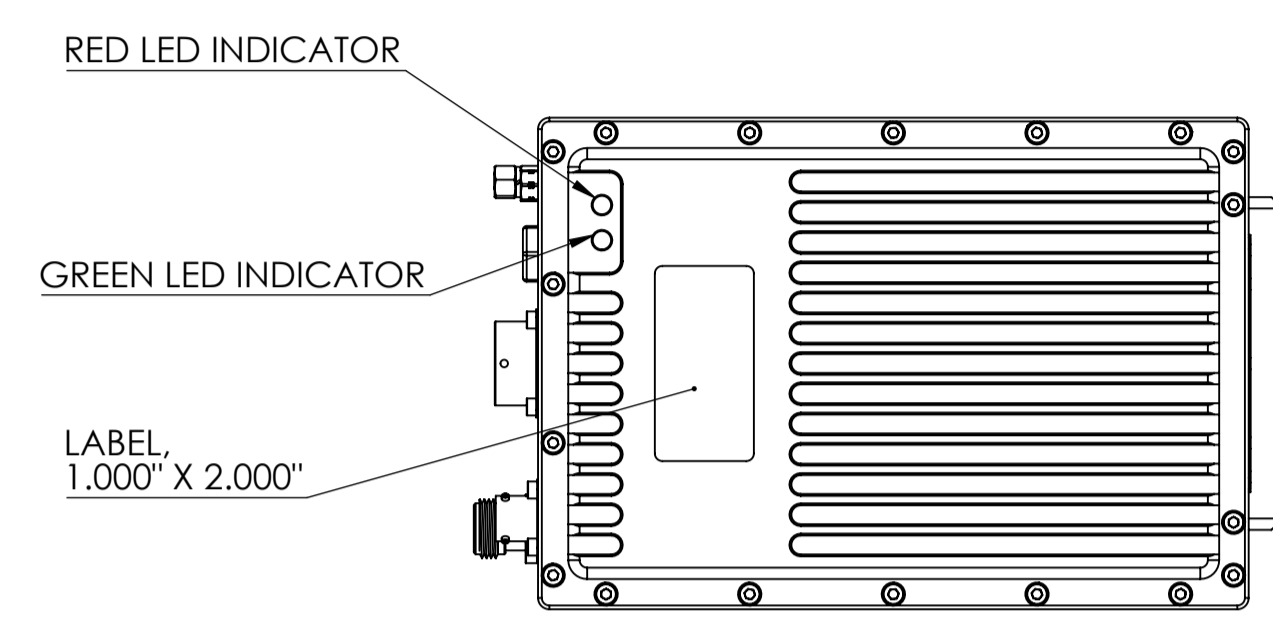

C

C

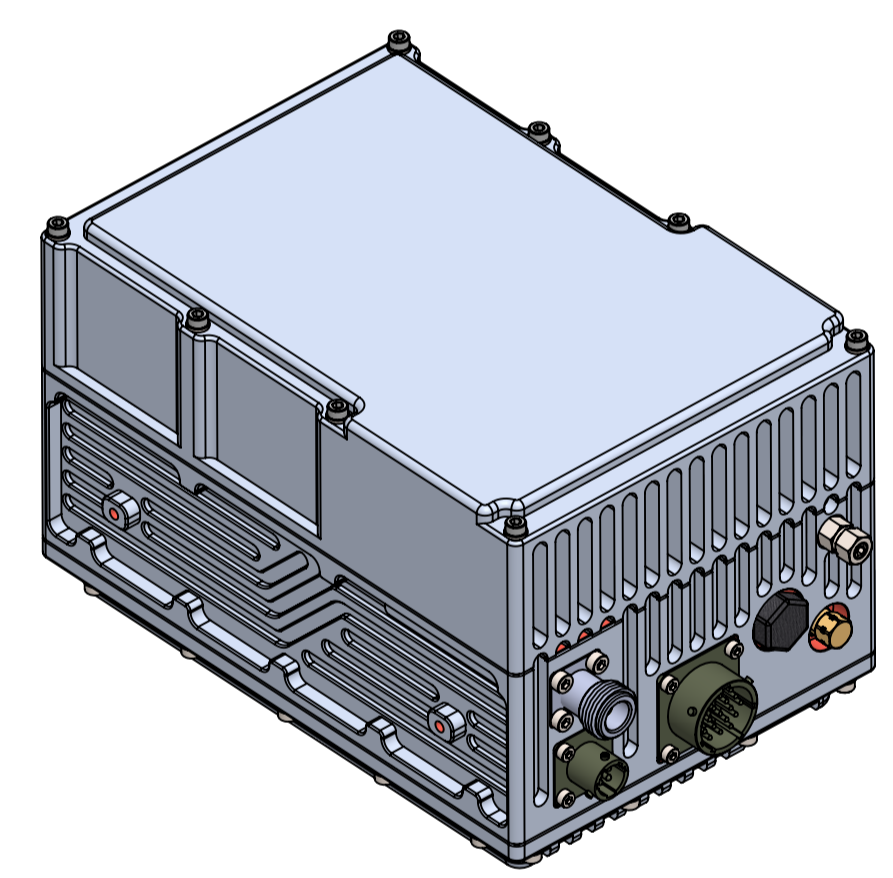
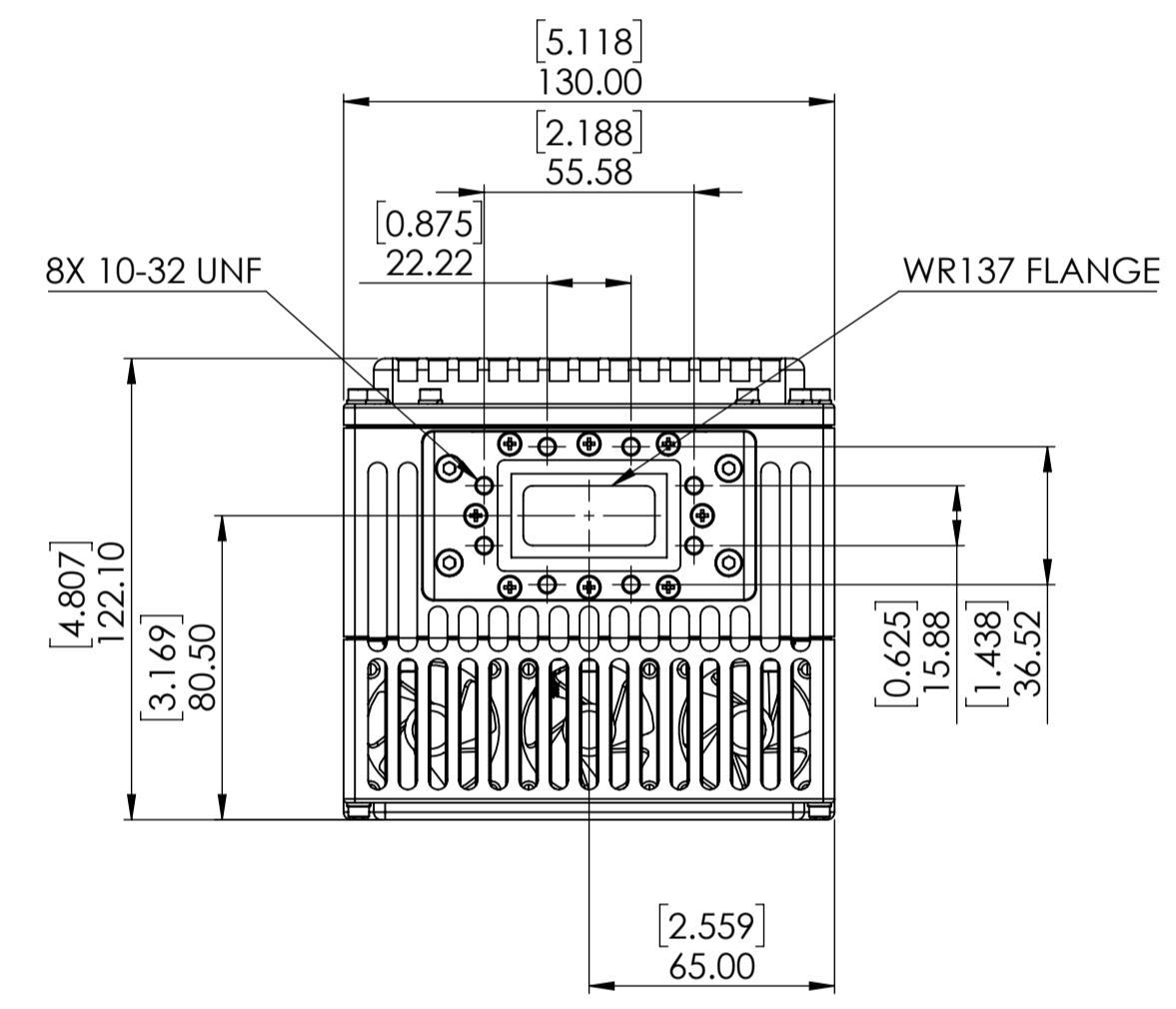
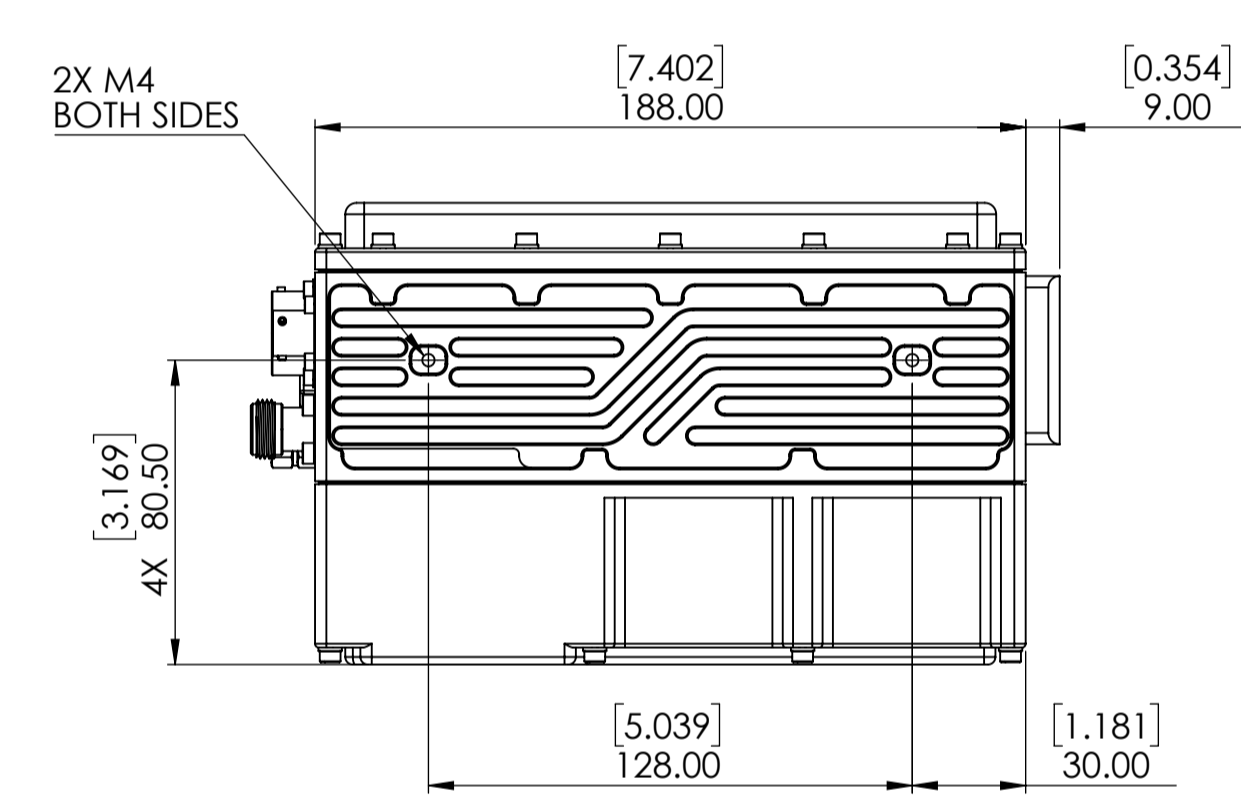
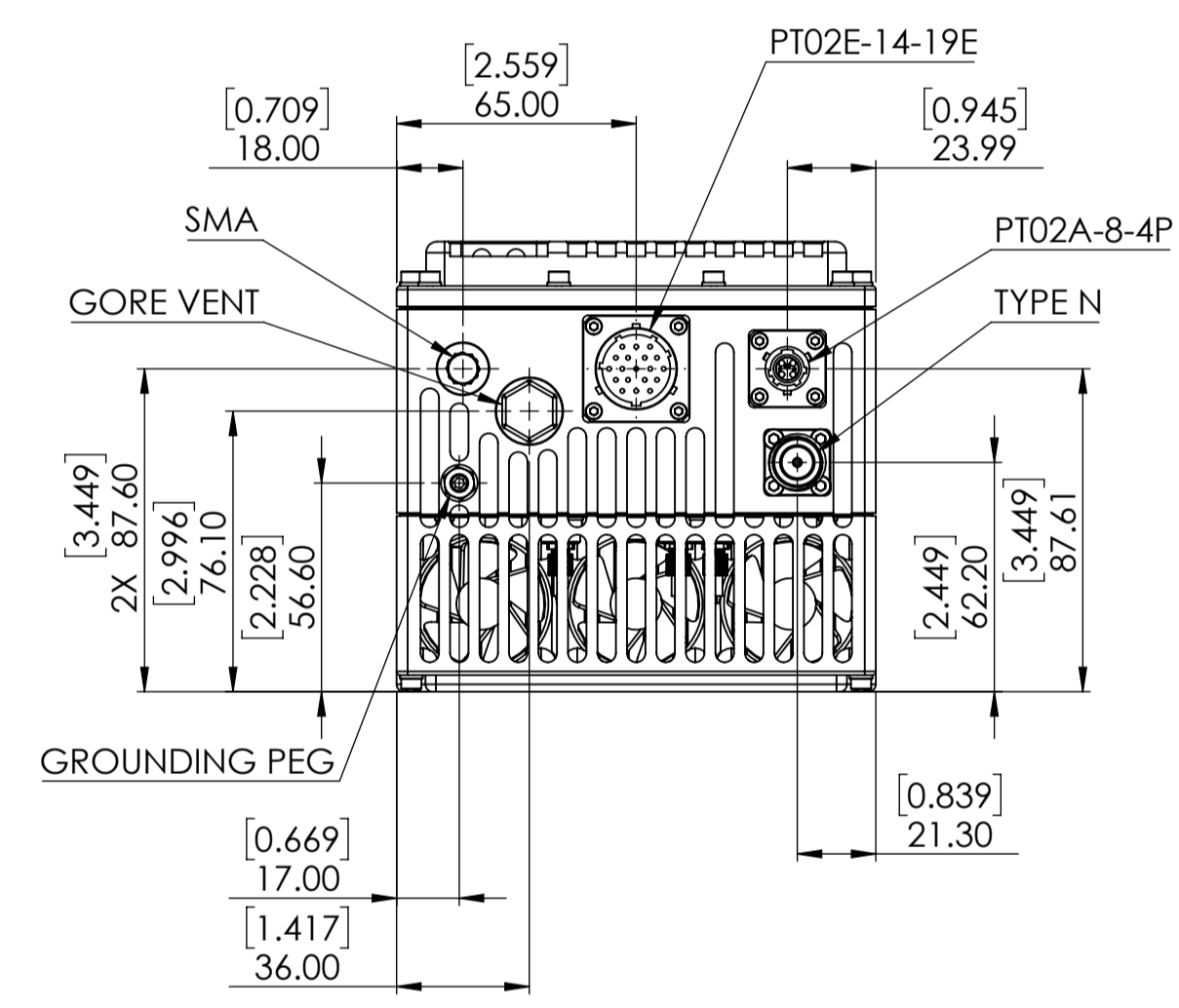

B

B

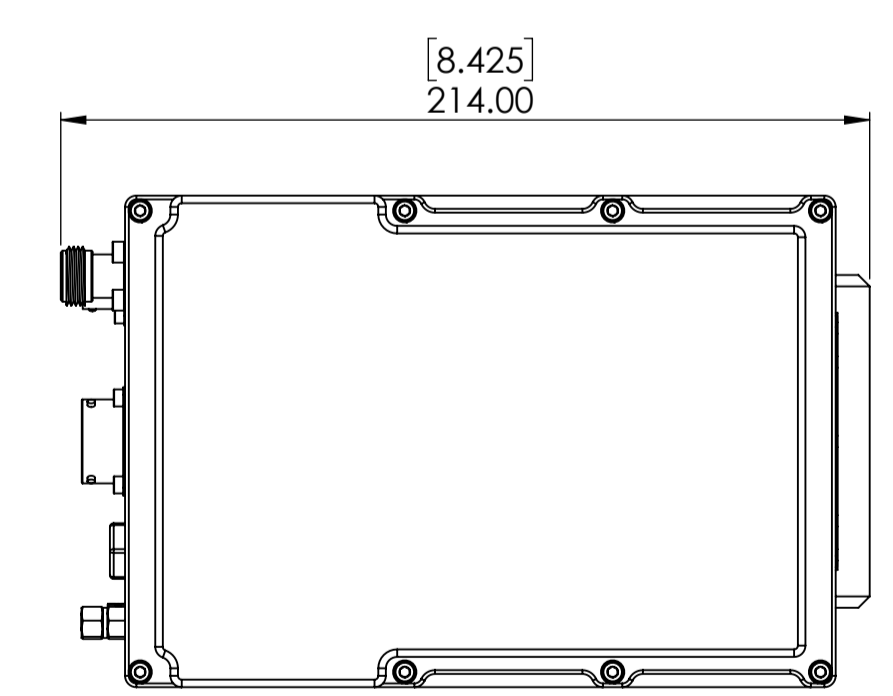

A

A

THIS DOCUMENT CONTAINS PROPRIETARY TRADE SECRET AND CONFIDENTIAL INFORMATION WHICH IS THE PROPERTY OF AMKOM DESIGN GROUP INC. THIS DOCUMENT AND THE INFORMATION IT CONTAINS ARE NOT TO BE COPIED, DISTRIBUTED, OR DISCLOSED TO OTHERS, OR USED IN ANY MANNER OUTSIDE OF AMKOM DESIGN GROUP INC WITHOUT PRIOR WRITTEN APPROVAL OF AMKOM DESIGN GROUP INC.

Amkom Design Group Inc.

UNLESS OTHERWISE SPECIFIED DIMENSIONS ARE IN MILLIMETERS. TOLERANCES AS SHOWN BELOW	
LINEAR	ANGULAR
X ± 1	X ± 2°
X.X ± 0.25	X.X ± 1°
X.XX ± 0.1	

INTERPRET DIMENSIONS AND TOLERANCES PER ISO OR ASME Y14.5M-1994
DIMENSIONS SHOWN ARE FINISHED SIZES AND SHALL ALLOW FOR PLATING AND COATING, BUT NOT PAINTING

DESCRIPTION
AMFC BUC, ASSEMBLY OVERALL DRAWING

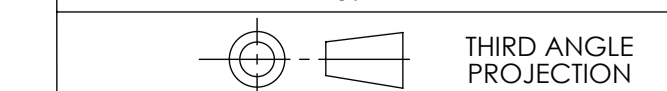

THIRD ANGLE PROJECTION
GENERAL THREAD FIT 6H 6g

SIZE	PART NUMBER	REV
A1	AMFC	A

8 7 6 5 4 3 2 1