

APK(S,D,L)80-150W

Ku-Band BUC High Temp +70C



FEATURES:

- Robust, Light Package Design Only 9.2lbs (4.2kg)
- Extreme Stability, Reliability and Performance
- Built-in HPA Overdrive Circuit Protection
- High Temperature Mode - up to + 70°C
- Built-in Optimized Linearization
- Built-in Receive Band Reject Filter
- Built-in Anti Vibration Technology
- Extreme GaN Linearity and Efficiency
- Exceeds ALL IESS-308/309 Phase Noise Standards
- Triple protection sealed waveguide output
- Field Replaceable IP68 (150,000 hr) Rated Fans
- Assembled and Rigorously Tested in California
- 3-Year Warranty



DESIGN OVERVIEW:

The "PHANTOM" series Extended (13.75 - 14.5GHz), Standard (14.0 - 14.5GHz) and Low (13.75 - 14.5GHz) Ku-Band BUCs are the next generation of the world's most efficient and compact-sized BUCs in the industry, weighing only 9.2 lbs (4.2 kg) and handling output power up to 150W at the Extended Ku-Band frequencies.

PERFORMANCE SPECIFICATIONS

Operating RF Frequency	APKS 14.0-14.5 GHz APKU 13.75-14.5 GHz APKL 12.75-13.25 GHz
Operating IF frequency	950-1450 MHz 950-1700 MHz
Local Oscillator	13.05 GHz 12.8 GHz 11.8 GHz
Rated Output Power PSAT Linear Power SR @ -26 dBc PLIN	APK80 80W 49.0 dBm 60W 47.8 dBm
	APK100 100W 50.0 dBm 80W 49.0 dBm
	APK125 125W 51.0 dBm 90W 49.5 dBm
	APK150 150W 51.8 dBm 100W 50.0 dBm
IMD3 (two tones) 3 dB Back Off (3.8 dB Back Off for APK150)	-25 dBc max. 2 signal 5 MHz apart at P-LINEAR
Spectral Regrowth at P-LINEAR (QPSK at 1.5x and OQPSK at 1.0x symbol rate offset with 2 dB back-off (2.8 dB back- off for APK150) from rated power)	-30 dBc
10 MHz External Ref. (Internal High Stability Optional)	10 MHz Ref. Level: 0 dBm +/- 5 dBm Internal Ref. Stability +/- 0.1 ppm

SPURIOUS & PHASE NOISE

In-Band/Out-Band Spurious	-60 dBc max.	
Group Delay	Ripple 1 nsec point-to-point max.	
AM/PM Conversion	1.0°/dB max. at 3 dB output backoff	
Noise Power Density (TX)	-85 dBm/Hz	
Noise Power Density (RX)	-155dBm/Hz (10.95 - 12.75 GHz)	
Phase Noise (Up Converter) (Ext. Ref.)	-55 dBc/Hz @ 10 Hz	-115 dBc/Hz
	-65 dBc/Hz @ 100 Hz	-135 dBc/Hz
	-75 dBc/Hz @ 1 kHz	-150 dBc/Hz
	-85 dBc/Hz @ 10 kHz	-155 dBc/Hz
	-95 dBc/Hz @ 100 kHz	-160 dBc/Hz

POWER CONSUMPTION

80W 49.0 dBm PSAT	370W
60W 47.8 dBm PLIN	290W
100W 50.0 dBm PSAT	470W
80W 49.0 dBm PLIN	370W
125W 51.0 dBm PSAT	590W
90W 49.5 dBm PLIN	440W
150W 51.8 dBm PSAT	700W
100W 50.0 dBm PLIN	490W

ENVIRONMENTAL SPECIFICATIONS

Environmental MIL-STD	Compliant with MIL-STD-810E/F,
Vibration MIL-STD	Method 514.5 C-2 Transport
Operating Temperature Range	- 40° C to + 70°C
Storage Temperature Range	- 60°C to + 85°C
Fan Rating / Field Replaceable	IP68, Field Interchangeable
Humidity	100% condensing, IP67-rated
Shock	20 g peak, 11 msec, 1/2 sine
Altitude	50,000 ft, 15,240 m

M&C INTERFACE

Advanced Monitor & Control	Ethernet Web Page Based, SNMP, RS232/485, FSK (opt.)
ALARMS	PLL LOCK, HPA, VSWR, MUTE, TX
Stealth PLin Operation Mode	LED Shut-Off Silenced fans

PROTECTION

VOLTAGE	OVERTEMP	VSWR
SMART ALARMS IN THE M&C	MICROPHONIC	CURRENT

COMPLIANCE INFORMATION

MIL-STD-188/164C	DO-160G	ROHS, REACH, WEEE
MIL-STD-461 E		

PART NUMBERING SYSTEM

AP - "PHANTOM" MODEL SERIES
 KL - Universal Ku-Band 13.75 - 14.50 GHz
 KS - Standard Ku-Band 14.0 - 14.50 GHz
 KL - Low Ku-Band 12.75 - 13.25 GHz
 80 | 100 | 125 | 150 - Rated Power in Watts
 N | F - 50 Ohm or 75 Ohm IF Input Connector Type
 M - M&C Option - RS232/485 + Ethernet + SNMP
 R - 10 MHz Ref. Auto Sense | Internal Reference
 K - FSK Option
 U - Universal Mounting Bracket
 J - Weatherproof DC/RJ45 Cable Dongle
 C xxxx - Custom RAL Color Code
 L - Custom Language
 P - Custom Part number
 B - Custom Label
 G - Custom Logo
 T- Redundancy Ready
 H - High Gain (+79 dB - 82 dB)
 W - Weatherproof Pelican Style Case
 O - Other Custom Option
 X - Custom Cable



Visit Product Page

Amkom Design Group Inc.

INPUT|OUTPUT INTERFACE

IF Connector	N-type (50 Ohm) F-type (75 Ohm)
Universal Prime Power via 3pin Power Connector	+ 85-260 VAC
Aphenol PT02E-12-3P, Current protection	
Output VSWR	1.5:1
Output Interface	WR75 Sealed & Grooved
Input VSWR	1.5:1
10 MHz External Ref. (Internal High Stability +/- 0.1 ppm Option Available)	10 MHz Ref. Level: 0 dBm +/- 5 dBm Internal Ref. Stability +/- 0.1 ppm

GAIN

Gain (Temperature Compensated)	75 dB (min) 80 dB (typ)
TX Gain Flatness	± 0.75 dB max. over 40 MHz
TX Gain variation 50 MHz	± 0.5 dB
TX Gain variation 500 MHz	± 1.5 dB
Built-in Receive Reject Filter	Suppression by +20 dB (min.)

MECHANICAL SPECIFICATIONS

Dimensions	8.5" x 5.2" x 4.54" (215 x 132 x 114 mm) Without Connectors
Weight	9.2 lbs (4.2 kg)

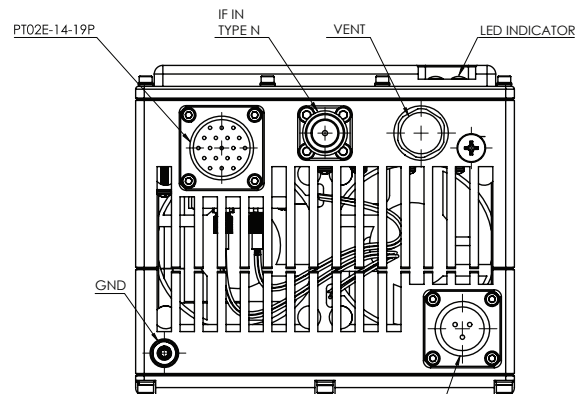
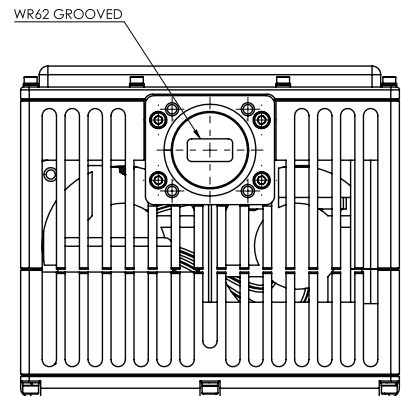

2892 S Santa Fe Ave, Bldg, 115 San Marcos CA 92069